

# ELK.

Lobe knobs



ELESA Original design



ERGOSTYLE®

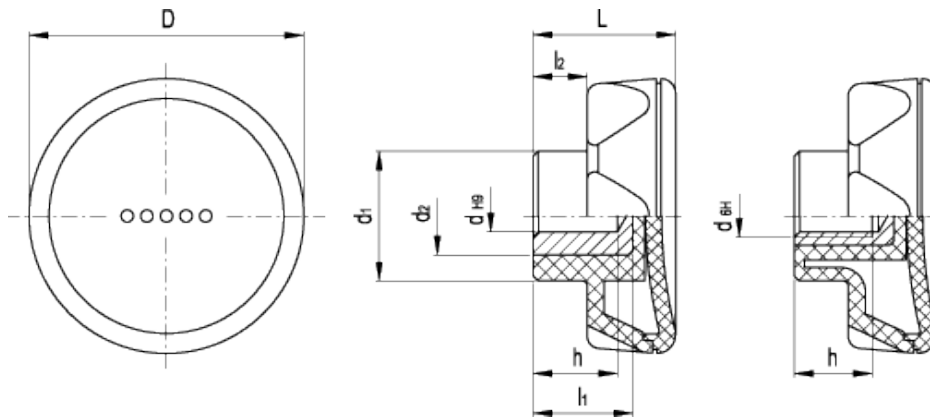

## technical informations

### Material

Glass-fibre reinforced polyamide based (PA) technopolymer. Resistant to solvents, oils, greases and other chemical agents.

### Colour

Grey-black, matte finish.

### Assembly

- Execution A: black-oxide steel boss, H9 reamed blind hole.
- Execution B: brass boss, tapped blind hole.

### Cap

Technopolymer in Ergostyle colours, matte finish. Ultrasonically welded to the body of the knob.

### Ergonomy and design

The slightly concave front surface and the rear finger grips guarantee an ergonomic position of the hand, allowing the operator

to apply the maximum torque with the minimum force.

**C1 RAL 7021** **C2 RAL 2004** **C3 RAL 7035** **C4 RAL 1021** **C5 RAL 5024** **C6 RAL 3000**

Standard Elements		Main dimensions						Mounting hole			Weight
Code	Description	D	L	d <sub>1</sub>	d <sub>2</sub>	l <sub>1</sub>	l <sub>2</sub>	d <sub>H9</sub>	d <sub>6H</sub>	h	g
221206-*	ELK.45 A-8-*	45	26	21	14	19	10	8	-	14	37
221221-*	ELK.45 B-M6-*	45	26	21	-	-	10	-	M6	12	29
221226-*	ELK.45 B-M8-*	45	26	21	-	-	10	-	M8	13	30
221406-*	ELK.56 A-8-*	56	29	26.5	14	18	11	8	-	14	53
221426-*	ELK.56 B-M8-*	56	29	26.5	-	-	11	-	M8	13	41
221431-*	ELK.56 B-M10-*	56	29	26.5	-	-	11	-	M10	13	39
221606-*	ELK.70 A-10-*	70	35	32.5	22	25	13	10	-	21	112
221631-*	ELK.70 B-M10-*	70	35	32.5	-	-	13	-	M10	18	68
221636-*	ELK.70 B-M12-*	70	35	32.5	-	-	13	-	M12	17	66

\* Complete the code and the description of the standard item needed by adding the index of the colour of the cap (C1,.....,C6) ex: 221206-C2 ELK.45 A-8-C2

This product had the following design awards:



ELESA and GANTER models all rights reserved in accordance with the law. Always mention the source when reproducing our drawings.

STANDARD MACHINE ELEMENTS WORLDWIDE